

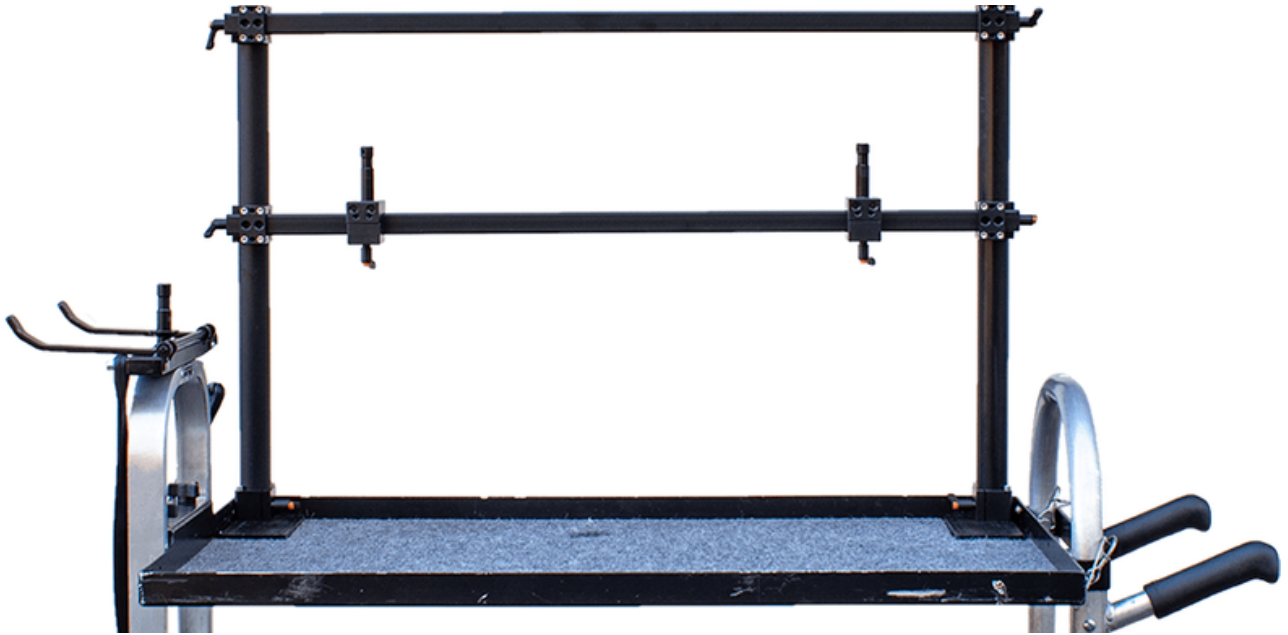

Whaley Rail II Assembly Instructions Backstage Magliner Cart



Congratulations on receiving your Whaley Rail II system! In order to properly install the Whaley Rail II frame, you will need to follow the provided assembly instructions.

Before installing the Whaley Rail II to your Backstage Magliner Cart, through holes will need to be drilled through the cart deck in order to mount the Whaley Rail Cheese plates. Mounting directly to the cart deck helps to ensure the load placed on the Whaley Rail II system is suitably balanced.

Tools Needed:

- 5-32 or 4mm Hex Key
- 3-16 Hex Key
- 7-32 Hex Key
- Utility Knife
- Hand Drill (with 17/64" or 9/32" or 6.8 - 7.2mm drill bits)

Table of Contents

03 Single Rail Components

04 Double Rail Components

05 Cheese Plate Mounting Instructions

07 Frame Assembly

08 Cross Rail Assembly

10 Rail Clamp to 5/8 Baby Pin

11 Production Monitor Mounting Options

12 Onboard Monitor Mounting Options

14 Whaley Rail II Accessories



Backstage Magliner Single Rail Base Assembly

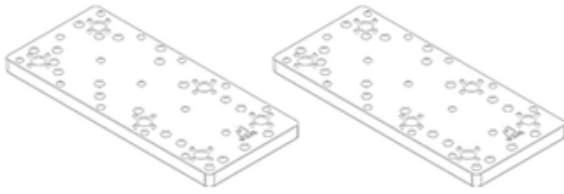

12720 - Deck Cheese Plate

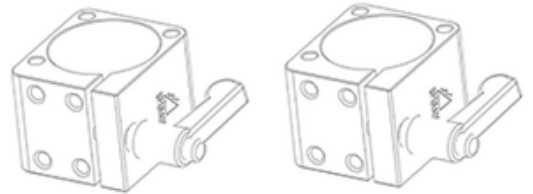

12725 - Deck Post Clamp

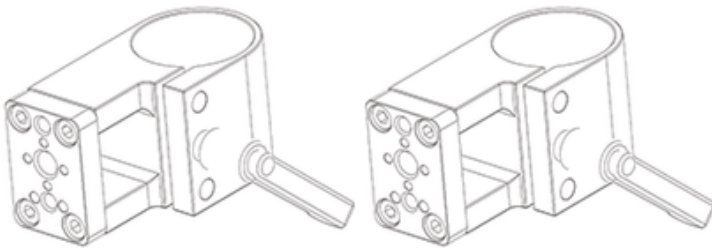

12599 - Corner Rail Clamp

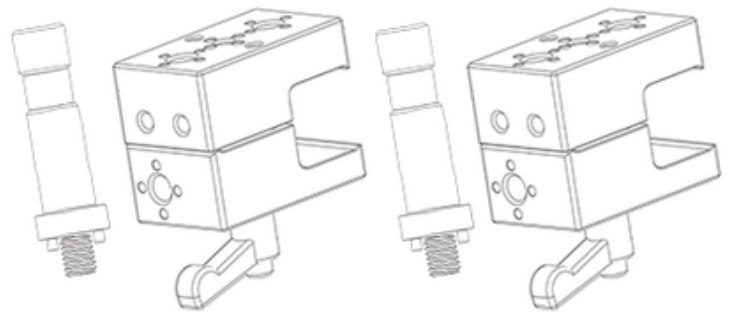

13640- Rail Clamp to
Whaley Pin-Loc 2.5" Baby Pin

24" Vertical Posts

Magliner Jr - 35.7" Rail



Weight

Magliner Jr Single Rail - 3.55kg/7.83lbs

Backstage Magliner Double Rail Base Assembly

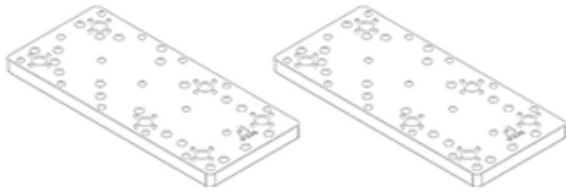

12720 - Deck Cheese Plate

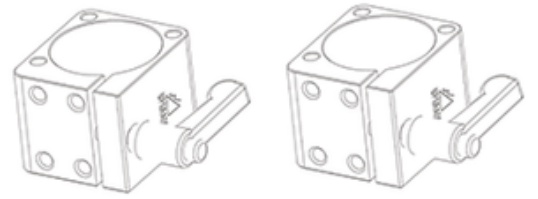

12725 - Deck Post Clamp

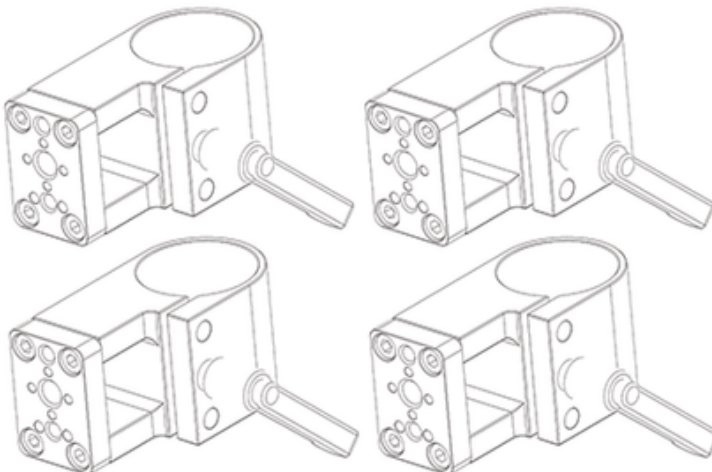

12599 - Corner Rail Clamp

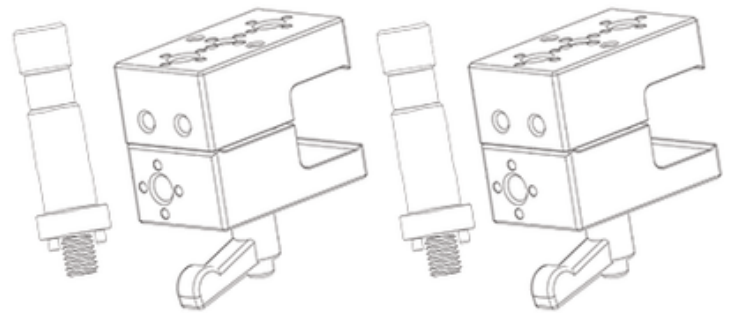

13640- Rail Clamp to Whaley Pin-Loc 2.5" Baby Pin

24" Vertical Posts

Magliner Jr - 35.7" Rail

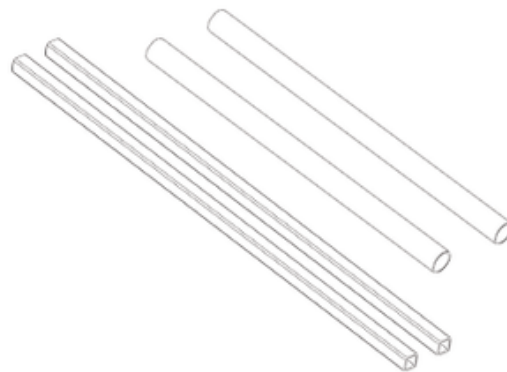

Weight

Magliner Jr Double Rail - 4.53kg/9.99lbs

Backstage Magliner Whaley Rail II Assembly Instructions

Cheese Plate Mounting Instructions:

We recommend mounting the cheese plates directly to the deck by cutting the carpet and drilling mounting holes. Determining the proper position of the cheese plate must be completed first.

To determine the mounting position on your cart deck see the photo below and measurements below.

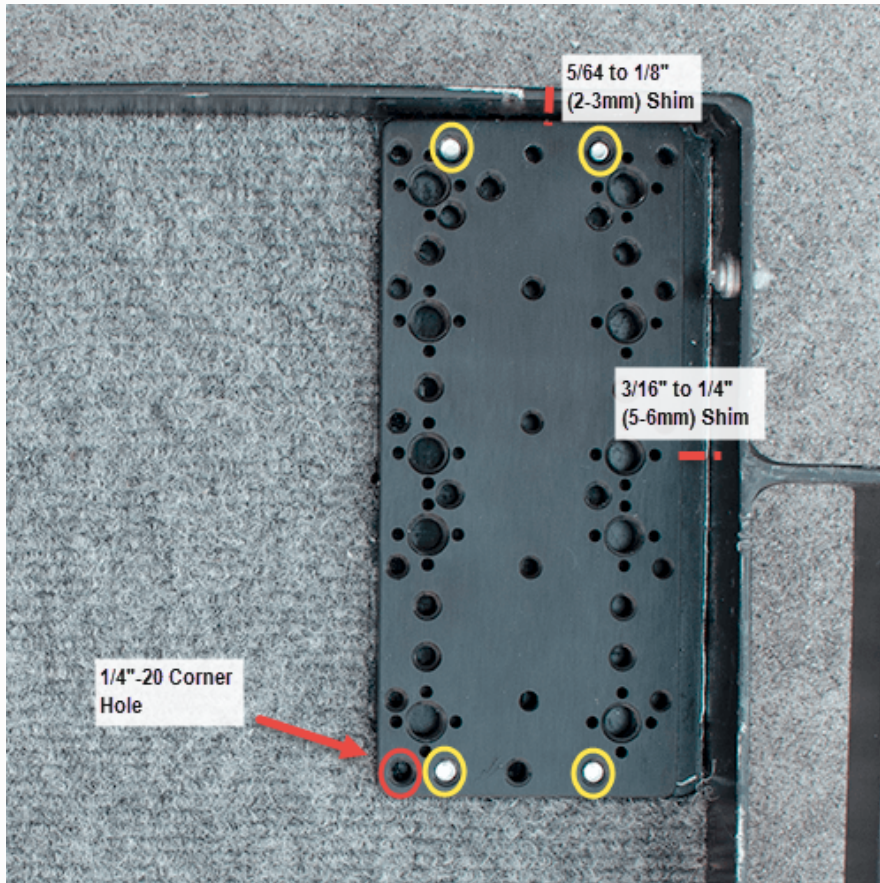

- Use a 5/64 - 1/8" (2-3mm) shim from the back wall to clear the cart deck back lip or overhang
- Use a 3/16" - 1/4" (5-6mm) shim from the side wall to clear cart deck lip.

Once the cheese plate is aligned, proceed to cut into the carpet with a utility knife, tracing the outline of the cheese plate. Repeat this same process on the other side of the cart.

Once you have removed the carpet from the deck, the cheese plates need to be properly oriented in order to determine where your mounting holes will be drilled. The cheese plates have a 1/4" tapped hole in one corner (see picture). This hole will be used to help you orient the cheese plates.



For both right and left side, have the 1/4" corner hole oriented towards the front and inside of the cart (see picture).

When the cheese plate is aligned and oriented you will now be able to mark your mounting hole positions on the deck. Magliner top decks will require four through holes to be drilled.

To mark the mounting hole positions, use the provided template or actual cheese plate. A 3/16" or 4.8mm drill bit or a transfer center punch can be used to mark the holes. We have highlighted the mounting holes on the template for you to easily identify them. Ensure the cheese plate or template remains in the proper position with the 3" and 3/8" shims when marking your holes.

***Tip: If using the cheese plate when marking mounting hole positions, be sure not to damage the tapped holes. To mark the deck with a drill, twist the drill by hand – do not use the power source as this could damage the tapped holes.**

Once you have marked your holes, remove your cheese plate or template from the cart deck. You are now ready to drill your through holes into the cart deck.

***Drilling can cause metal shavings to get caught in the cart decks carpet. Prepare the drilling area with tape and paper so that cleanup is easier. Ensure the mounting area has been cleaned before mounting the cheese plates.**

The following drill bit sizes should work for drilling the through hole:

Metric:

6.8mm drill or 7.2mm drill

Imperial:

Fraction sized drill 17/64" (0.265") or 9/32" (0.281")

After you have drilled the through holes, align the holes with the mounting tapped holes on the cheese plate. To mount the cheese plate, use the supplied Socket Head Cap 1/4-20" x 1/2" screws with a single washer.

Before tightening, double check the cheese plate alignment. Repeat all steps on the other side of your cart.

Frame Assembly

The symmetrical mounting patterns of the deck mounted cheese plates allow the user to customize their frames location on the cart deck. Six positions are possible for the deck posts, allowing you to also choose the position of the levers.

Having the frame mounted towards the back of the cart increases the forward deck space. When the frame is mounted forward on the cheese plates, it increases backend spacing.

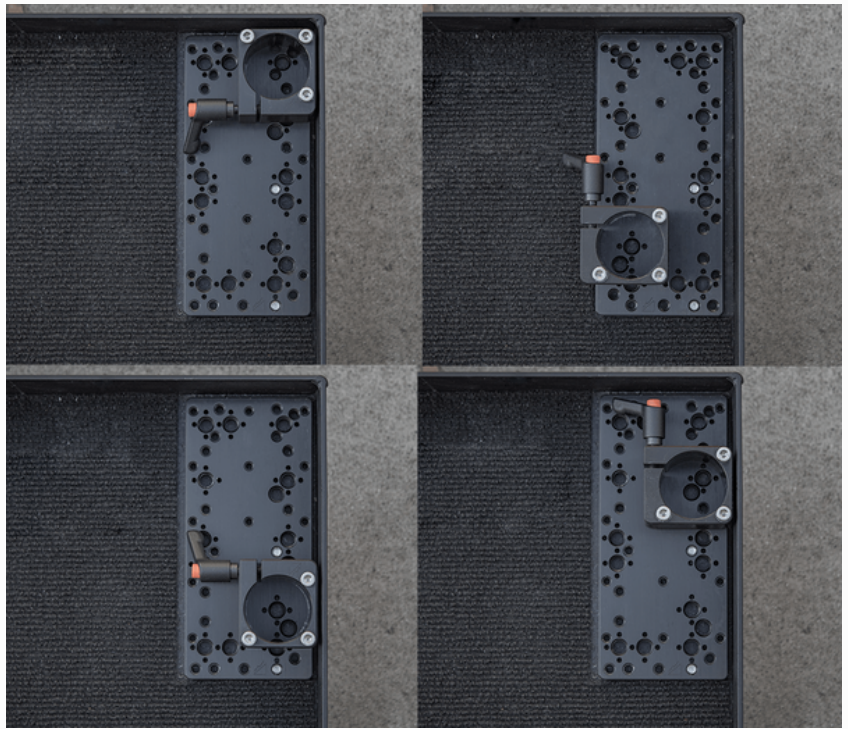

This helps to ensure that components mounted on the rail system can properly fit within the cart's framework, which is especially important to consider when pushing your cart through tight spaces. Having this setup avoids the need for possible onset adjustments, saving you valuable time.

Use the supplied M5 x 45mm socket head cap screw (SHCS) to tighten the post clamp to the cheese plate with a 5-32 or 4mm Hex Key.

***Tip: If the lever is not needed, it can be replaced with the provided M6 x 30mm SHCS.**

Mount both of the 1.5" Vertical Posts into the Deck Post Clamps and tighten the adjustable lever or the SHCS.



Cross Rail Assembly

Corner Rail Clamps are either mounted with the cross rails facing either forwards or backwards to the vertical post. Our recommendation for the monitor cross rails is to have them facing forwards (the rounded side is facing towards the back of the cart).

Slide both of the Corner Rail Clamps all the way down each vertical post, resting on the deck post clamp, to install cross rail. **Installing the rail at this lower position ensures the vertical posts are parallel once frame is assembled.** The recommended position is with the adjustable lever facing outwards, to allow for easy adjusting.

With the clamping mount plate loose, insert the 1" Square Rail into the Corner Rail Clamp on one side before guiding the rail into the second clamp. Center the cross rail ends evenly between the corner rail clamps

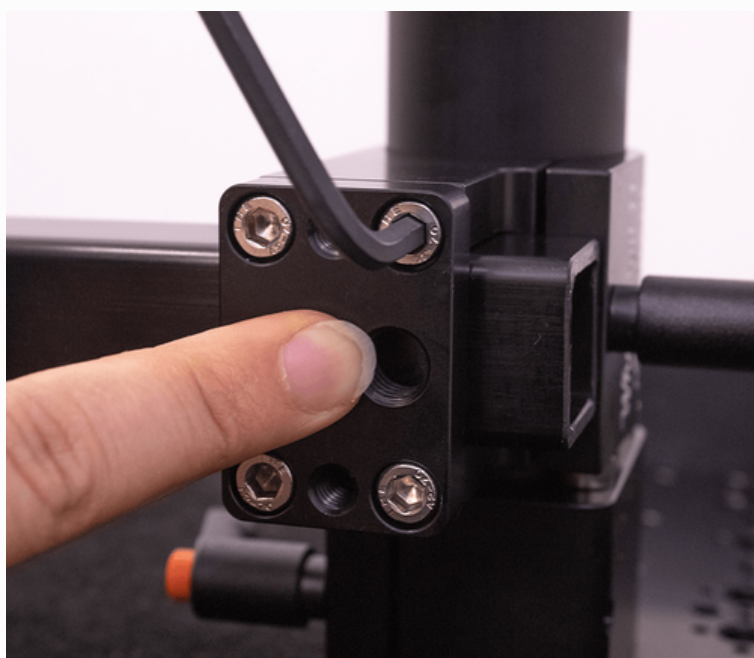

With the rail centered, push the clamping mount plate against the rail and tighten the M5 x 16mm SHCS in a criss-cross sequence (alternating between top and bottom screws) to keep the plate flat. Repeat this procedure on both sides prior to fully tightening screws, to ensure balanced mounting.

Once both mounting plates are snug against the rail, tighten the adjustable levers and finish tightening the mounting plate screws.

Important: With cart assembled, install the rails at the lowest possible position on the vertical posts. This ensures the vertical posts are parallel once frame is assembled. This will help to slide rails evenly along vertical posts.

For Double Rail setups, assemble the second rail following the above instructions. However, this time you will want to slide the second set of corner rail clamps all the way down the vertical posts to rest on top of the first set of installed corner rail clamps.

Once the rails are mounted and aligned, it should not be necessary to loosen the mounting plate screws. Simply loosen the adjustable levers to adjust the rail height and evenly slide the rails up and down.

Note: The rails can become stuck if slid unevenly. If you are unsure which side needs adjustment, measure or compare the heights before you apply any force.

As previously mentioned, and shown in the above image, the cross rails can be mounted either forwards or backwards on the vertical posts. Having the monitor cross rail mounted forwards and the secondary rail mounted backwards, can help to create much needed space behind the monitors, for mounting accessories and components.

***Tip: If the levers are not desired, they can be replaced with provided M6 x 30mm SHCS.**



Rail Clamp to Whaley Pin-Loc Baby Pin

You are now ready to place your rail clamps.

Extremely solid clamp, rated for heavy production monitors.

Check out the Production Monitor Mounting Options section for monitor mounting options.

The Rail Clamps are easily placed on the horizontal rails or quick released off with two full turns of the adjustable lever.

***Tip: If the levers are not desired, they can be replaced with provided M5 x 40mm SHCS.**

The Whaley Pin-Loc 5/8 Baby Pin can be mounted to the ARRI 3/8-16" pin-loc mounting patterns on the Rail Clamp.

Use a 5/32 or 4mm hex key to tighten the Whaley Pin-Loc 5/8 Baby Pin.

The Rail Clamp has ARRI 3/8-16" pin-loc and SmallHD 1/4-20" pin-loc tapped holes on various sides for further mounting options.

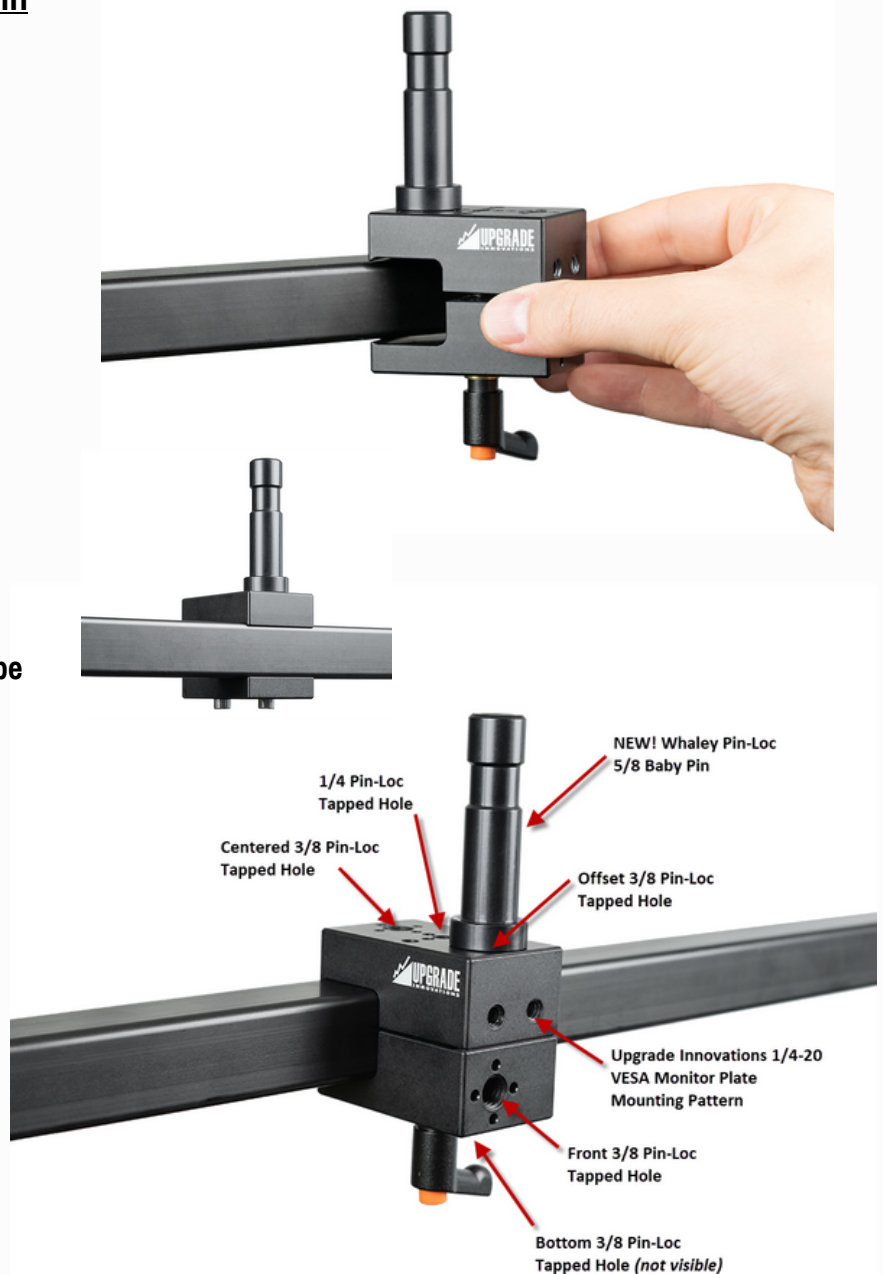

NEW – Rail Clamp now features the Whaley Pin-Loc 5/8 Baby Pin. The pin-loc design will prevent baby pin from twisting loose from cart forces/vibration.

Note: Whaley Pin-Loc is matching the design of the ARRI pin-loc standard, however with a longer 3/8-16 thread for a more rigid anchor point.

Setup Tip: The design of the Rail Clamp is meant to be removable and attached directly to a cross rail as needed, however if a user is looking for a "captive" Rail Clamp setup, this is also possible!

For this setup, the two provided M5 SHCS will need to be used. Apply a bit of removable Loctite to both M5 screws and thread both into the Rail Clamp (best to do this while it is already installed to the cross rail).

Once both screws are tightened, loosen each screw slightly so that when the adjustable lever is loosened, the Rail Clamp can still slide horizontally. The screws will prevent the Rail Clamp from opening fully to disengage from the cross rail, which can be beneficial for some setups!

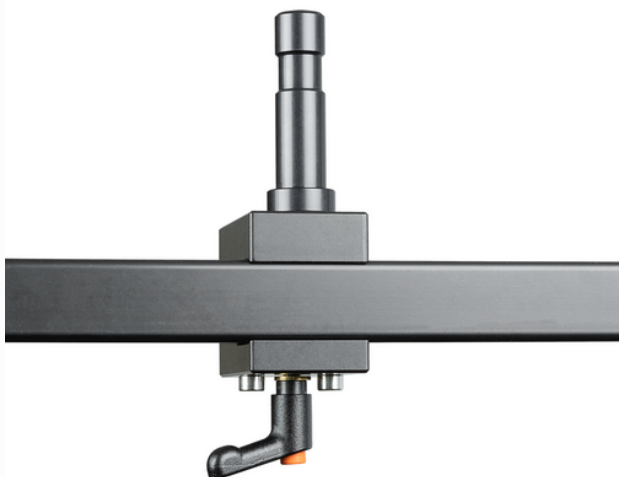

Production Monitor Mounting Options

The Whaley Rail II basic system is outfitted with two Rail Clamps to 2.5" Baby Pins.

For users looking for a complete system, Upgrade Innovations offers professional monitor mounting solutions for mobile and studio applications. See below for various accessories.



Rail Clamp to Quick Release VESA Plate

Mount QR plate directly to Rail Clamp via 1/4-20" mounting pattern.

Incredibly rigid mounting setup.

Quickly release monitors for packing.



Rail Clamp to Quick Release - Landscape/Portrait VESA Plate

Mount QR plate directly to Rail Clamp via 1/4-20" mounting pattern.

Incredibly rigid mounting setup.

Quickly release monitors for packing.



MMS09 VESA Monitor Mount to 5/8" Spigot - Ball-Loc

Available with Standard VESA Monitor Plate, Quick Release, Landscape/Portrait or Quick Release-Landscape/Portrait

Designed for Mobile/Cart Applications with our positive locking ball-lock hinge system

Production Monitor Mounting Options Cont.



MMS11-MC VESA Monitor Mount to 5/8" Spigot – Twin Ball-Loc

Available with Standard VESA Monitor Plate, Quick Release, Landscape/Portrait or Quick Release-Landscape/Portrait

Designed for Mobile/Car Applications with our positive locking ball-lock hinge system

Onboard Monitor and Accessory Mounting Options



Rudy Arm Articulating Arm System

Industry tough articulating arm that is built for universal use.

Anchor arm with our positive locking ball-lock pivot clamps, while making use of the friction-lock pivot clamp to set viewing angle on monitor.

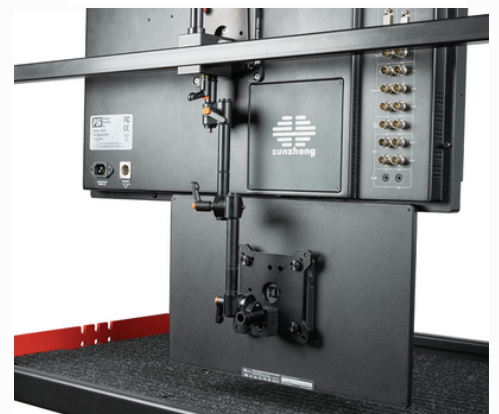

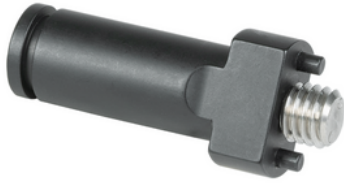

ARRI 3/8 Pin-Loc 15mm Mounting Spud

Arri 3/8" Pin-Loc compatible, ideal choice for a solid mounting option for 15mm accessories



SmallHD 1/4 Pin-Loc 15mm Mounting Spud

The SmallHD 15mm Mounting Spud - 1/4" Pin-loc are specifically machined to securely hold your SmallHD monitors in place. Also compatible with a lot of Upgrade Innovations mounting brackets.



Leader LV Non-Twist Mounting Plate

Mount to Leader 5333, 5330, 5381, 5380, 5382 models adding ARRI 3/8" Pin-Lock and SmallHD 1/4 Pin-Lock.



Leader LV5350 Non-Twist Mounting Plate

Mount to Leader 5350 models adding ARRI 3/8" Pin-Lock and SmallHD 1/4 Pin-Lock.



Rudy Arm Pin-Loc Adapter for VESA Plate

Attaches to our VESA Mounting Plates via the 1/4-20 Flat Head Mounting Pattern to provide industry standard SmallHD 1/4" Pin-Loc and ARRI 3/8" Pin-Loc mounting patterns.



Cine Mounty 3 Cargo Mounting Plate

The Cine Mounty 3 is perfect for when you need to solid mount a small monitor. Removable rubber keepers, a built in rubber pad and a 1/4-20 knob screw keep your accessory from twisting loose.

Whaley Rail II Accessories



Whaley Rail II – Rail Clamp to 2.5" Whaley Pin-Loc Baby Pin **NEW**

Add additional rail clamps to your system for further mounting options!

The 2.5" long non-twist Whaley Pin-Loc baby pins are also available separately.



Whaley Rail II – Rail Clamp to 6.6" Whaley Pin-Loc Baby Pin **NEW**

Add additional rail clamps to your system for further mounting options!

The 6.6" long non-twist Whaley Pin-Loc baby pins are also available separately.



Whaley Rail II – Vertical Post End Plug to 3/8"

End Plug jams into our 1.5" Vertical Post by using a 5/32 or 4mm Allen Key to provide a 3/8" pin-loc tapped hole for mounting further accessories.

